

## Models

For both SJ and MA screwjacks there is a choice between two models:

**Model A**      **travelling screw**

**Model B**      **travelling nut**

Your choice here depends on the configuration of the application, also the options required. Performance is the same for both models.

Servomech screw jacks can be operated in vertical or horizontal planes, or angles in-between. Input options are male shaft, motor flange or second shaft.

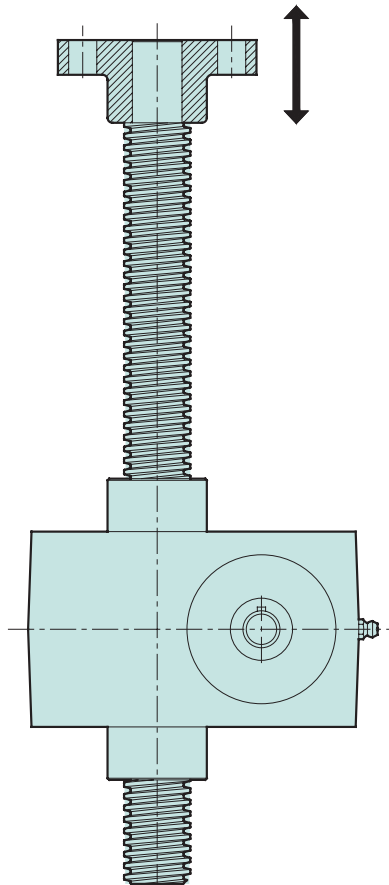

*Model A – travelling screw*

Travelling screw models operate with the screw being driven through the centre of the wormwheel. In operation, the screw does not rotate. Space must be available for the screw to protrude below the gearhousing when in a fully closed position.

Typical options:

- protective tube
- bellows
- spiral spring protection
- safety bronze nut
- variable screw end fixings
- limit switches
- anti-turn device
- wear indicator switch
- stop nut
- trunnion mounting
- stainless steel acme screw
- bronze guide bushes

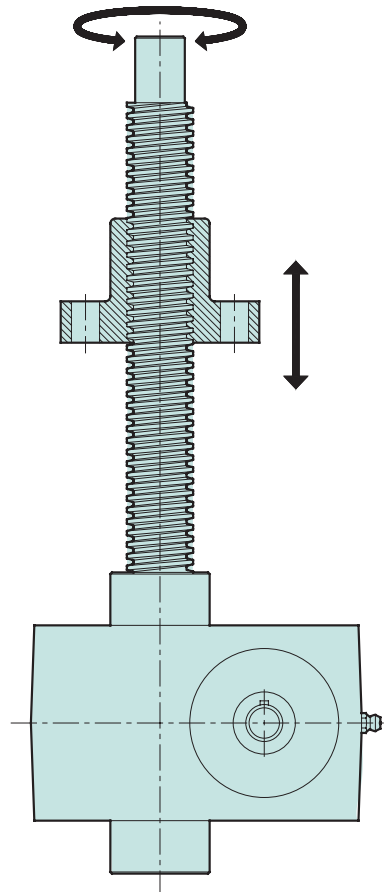

*Model B – travelling nut*

Travelling nut models have the screw fixed to the wormwheel. In operation the screw rotates with the wormwheel, driving the nut up and down. Overall dimensions for this combination remain fixed.

Typical options:

- bellows
- safety travelling nut
- wear indicator switch
- stainless steel acme screw
- trunnion mounting travelling nut
- travelling nut at customer's drawing

## SJ Series Screw Jacks

Attractive low cost screw jacks series

- Long life grease lubricant for worm gear
- Compact monobloc housing, cubic design, for high static load capacity
- Acme screws two or three start threads available
- Wide range of input versions and accessories available



**Example  
SJ model B  
travelling nut**

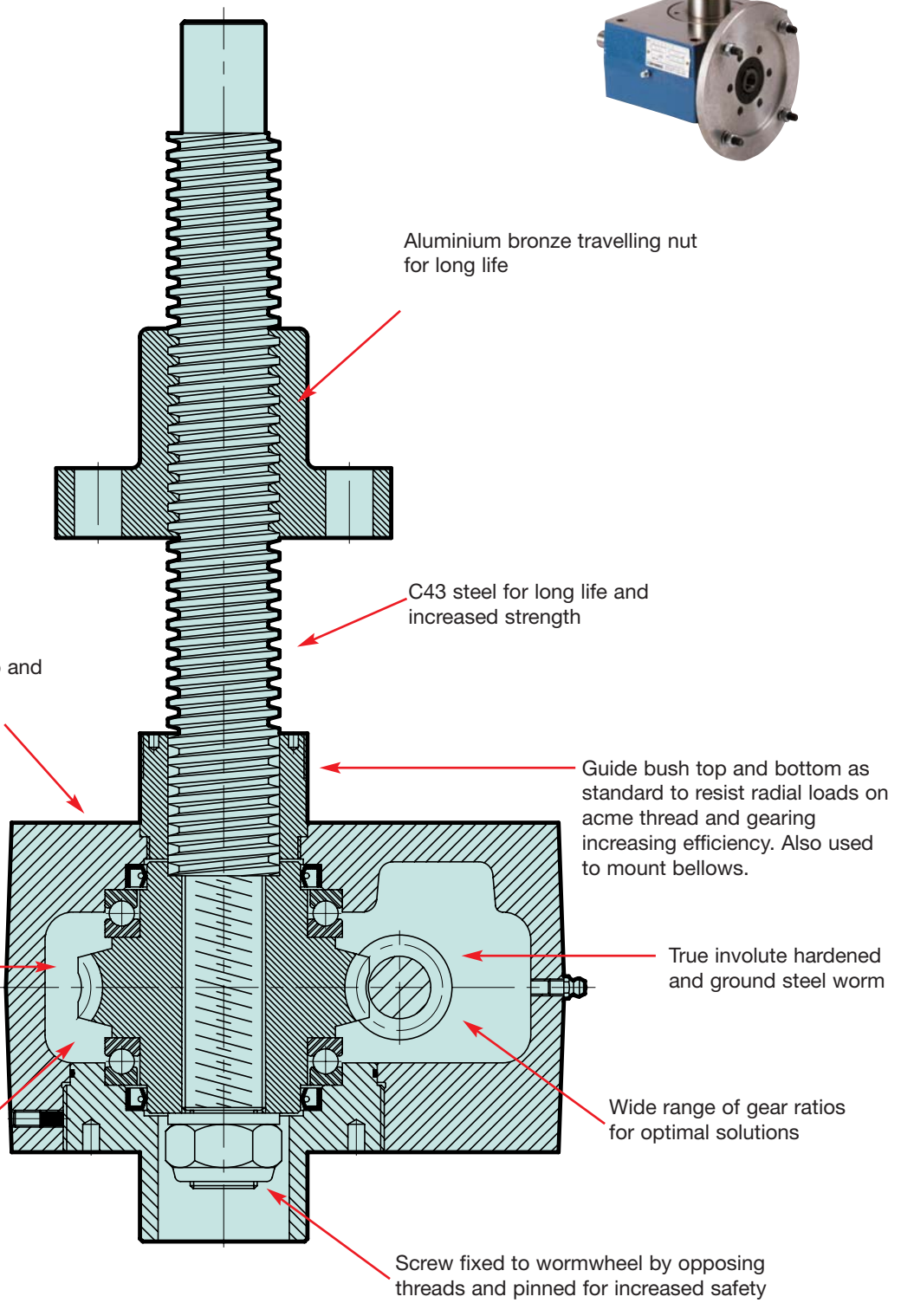

# MA Series Screw Jacks

High efficiency screw jacks series

- Long life oil lubricant for worm gear
- Modern gear housing design for heat dissipation
- High efficiency allowing high speed and high duty applications
- Ballscrews and two, three or four start threads available
- Extensive range of options features and accessories



**Example  
MA model A  
travelling screw**

Long bronze wormwheel for increased rigidity, duty, life and efficiency

Oil lubricated for better heat dissipation, allowing higher input speeds and giving a longer life and increased efficiency

